

2 4 7 - 3 3 5 N E T H O R S E P O W E R



JOHN DEERE

J

DOZERS

950J | 1050J



Push the limits.



950J

247 net hp

56,361 lb. w/Semi-U Blade; 59,255 lb. w/ Straight Blade

22-, 24-, 26-, 32-, and 36-in. grousers

12-ft. 1-in. and 14-ft. 10-in. blades

Big, strong, and powerful, the 950J and 1050J Dozers deliver the super-sized performance you need to get the big jobs done. But it's not just their large stature that make these dozers such valuable assets. Like their J-Series siblings, these two offer many of the production-boosting advantages that have made Deere crawlers so popular,

including state-of-the-art electronic controls, Total Machine Control (TMC), and a full-featured hydrostatic drivetrain. You simply won't find comparable-size crawlers with the same combination of power, control, reliability, and comfort. Read on to learn how the 950J and 1050J will help you push productivity beyond the limits of other dozers.



1050J

335 net hp

86,800 lb. w/Semi-U Blade; 89,250 lb. w/Straight Blade

22-, 24-, and 28-in. grouters

13-ft. 3-in. and 14-ft. 2-in. blades

Slow-running Tier 3 diesels deliver impressive power, torque, and drawbar pull for unsurpassed productivity.

Hydraulic-driven variable-speed suction fan runs only as needed, reducing noise, fuel consumption, cooling system wear, and operating costs.

Power turns, power management, infinite speed control — John Deere introduced them all 30 years ago. And the 950J and 1050J Dozers are loaded with even more productivity- and uptime-boosting enhancements.

Comfort and convenience are noticeably enhanced in the quieter, more spacious redesigned cab.

Extended service intervals, remote test ports, and designed-in diagnostics keep maintenance and operating costs to a minimum.



Infinitely variable track control lets an operator speed up or slow power to either track, for smooth, full-power turns.



Counterrotation is a productivity-boosting feature that enables an operator to overcome heavy corner loads and quickly reposition the blade on the go. Provides space-saving spot turns, too.



These dozers steer the same and maintain their preset speed whether working on level ground or a 2-1 slope.

Serious productivity, easy-going control.

Size matters on large-scale construction sites. With their superior power-to-weight ratios, 950J and 1050J simply outpush every dozer in their class. And do so with less effort. State-of-the-art controls and full-featured hydrostatic drivetrains put you in complete command of a whole arsenal

of productivity-boosting hydrostatic advantages including power turns, counterrotation, infinitely variable travel speeds, and dynamic braking. With conventional powershift torque converter drivetrains and differential steering systems, other crawlers simply can't do what a John Deere can.



Variable-pitch parallelogram single- or multi-shank rippers can be angled on-the-go, for increased productivity.

Power management takes the guesswork out of efficient operation. The operator simply sets the desired maximum ground-speed and the system automatically maintains peak engine rpm and power efficiency without stalling or shifting.

Infinitely variable speed range from standstill to 6.8 mph gives total flexibility to match groundspeed to the load. Travel can also be varied to fit specific applications, terrain, or operating preferences—and even limited to maximize under-carriage life.

Blade pitch is adjustable to three mount locations, for superior performance in a variety of applications and materials. Unlike other dozers, tilt cylinder pitch can also be set to maintain equal tilt. A hydraulic pitch option is available.

Blade curvature gets material rolling and fills more fully for increased productivity.





Convenient 12-volt port powers cell phones and other electronic devices.

Take comfort in more productivity.

Like all Deere dozers, state-of-the-art short-throw, low-effort blade and speed-in-grip hydrostatic drivetrain controls deliver predictable response at all times.

Retractable seat belt, slip-resistant floor mat, convenient grab bars, neutral-start lever, and automatic park brake help keep the operator out of harm's way.

Deluxe suspension high-back seat adjusts seven ways for daylong comfort and is angled 15 degrees to provide a more comfortable view of the ripper. Armrests and footrests are also fully adjustable to fit any size operator.

Decelerator slows ground-speeds to maintain speed and traction without affecting engine power and hydraulic response. Fully depressing the pedal applies the brakes.

TMC lets you customize decelerator mode and response, forward/reverse groundspeed ranges, FNR shift rate, and forward/reverse speed ratios for superb control.

Everybody knows a comfortable operator is a productive operator. And you'll find plenty to increase their efficiency inside this spacious and quiet walk-through cab. The seven-way adjustable deluxe suspension armchair, low-effort intuitive controls, and best-in-class visibility keep fatigue to a minimum. Plus you get the little things that help shorten a long shift—such as adjustable footrests and ample storage including cup holder and space for a lunch box.



Wide expanse of glass and exclusive four-post ROPS provide an unsurpassed commanding view of the blade, ripper, and surrounding jobsite.



Ergonomically designed joystick provides intuitive control of steering, forward/reverse travel, and ground-speed. It's detented so it doesn't require constant attention, and employs a finger-actuated travel-speed switch.



Air-conditioned and heated pressurized cab is standard. Automotive-style directional vents help keep the glass clear and interior comfortable.



Enhanced monitor is front-mounted, where it is easier to view while focusing on the job at hand. Large, easy-to-read gauges, warning lights, and icons provide vital operating info at a glance.



Pilot control and load-sensing hydraulics deliver fatigue-beating low-effort operation and predictable response, regardless of the load.

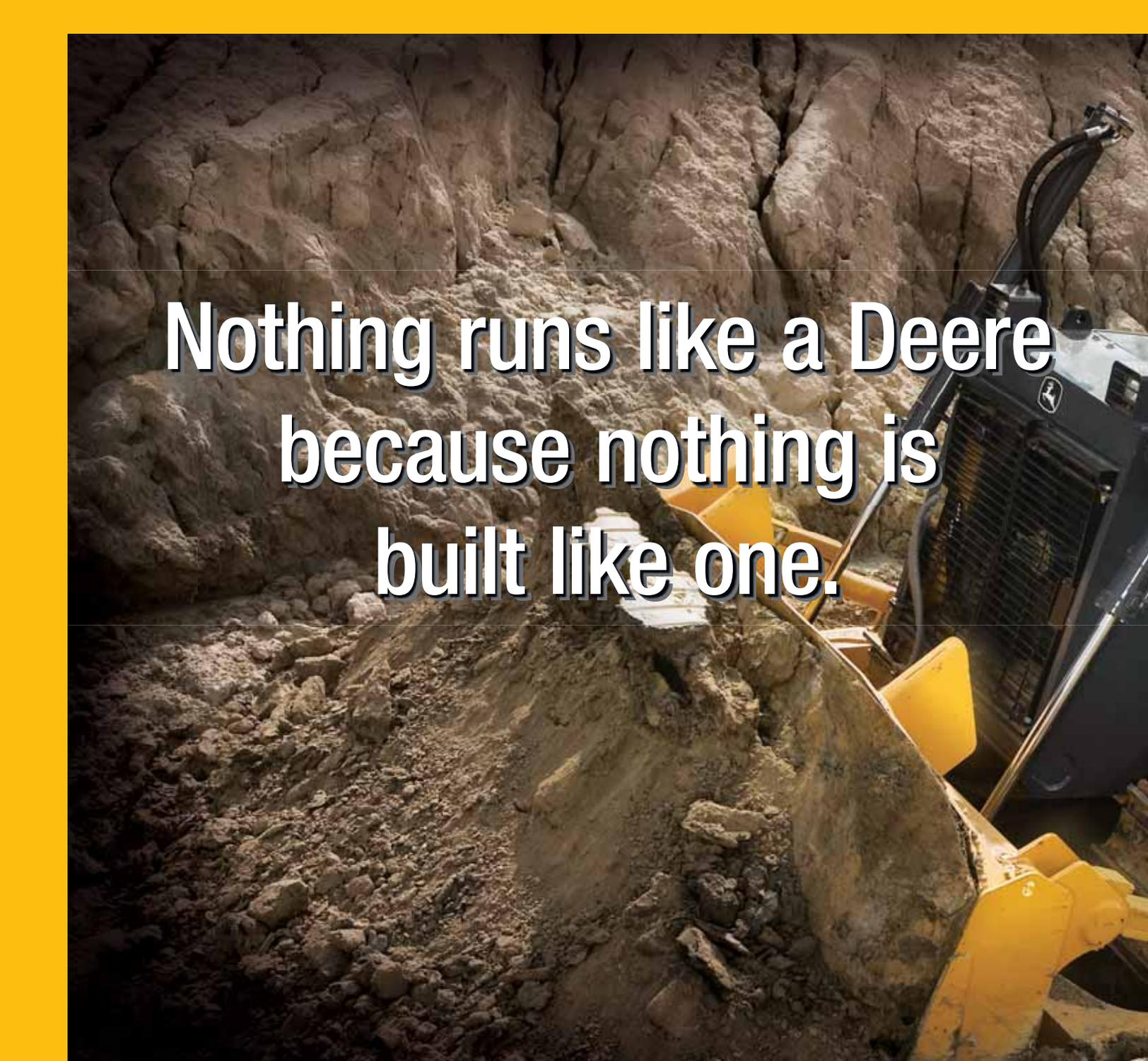

**Nothing runs like a Deere
because nothing is
built like one.**

Downtime is a fact of life in this business. Fight back with the J-Series. Incorporating numerous traditional John Deere durability features, you get an exceptionally strong unitized mainframe, job-proven undercarriage, heavy-duty wet-sleeve engine, reliable ORFS hose couplings, heavy-duty

high-pressure hoses, and isolated planetary final drives. Other enhancements such as a variable-speed hydraulic-driven fan, sealed electrical connectors, and extended service intervals all help keep you, and your operation, up and running. When you know how they're built, you'll run a Deere.

Coolers' wide fin spacing lets trash pass to resist plugging. Available reversing fan backblows cooler cores, further reducing debris buildup.

Hydraulic-driven variable-speed engine fan runs only as needed, decreasing noise and fuel consumption.

Wet-sleeve diesels deliver maximum power at low 1,600 rpm for outstanding reliability. It's surprisingly quiet and exceptionally fuel efficient, too.



Separate engine and transmission cooling systems employ hydraulic-driven fans for superior cooling efficiency.



Half-shell push-beam bearings make cutting and welding unnecessary, so they're less costly and time-consuming to replace.

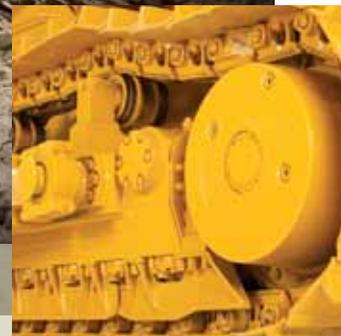

Heavy-duty undercarriage is sealed, lubricated, and built to last. Its no-nonsense oval-track design has only one wear-causing forward-travel flex point, for longer life.

Oscillating track frames absorb shock loads, for lasting durability, better gradeability, and more comfort. Plus a smaller diameter front idler improves visibility.

One-piece totally welded mainframe resists torsional stress, absorbs shock loads, and delivers maximum strength. Allows simplified service access to major components, too.

Final drives incorporate a unique oil-filled double seal. If oil escapes past the first seal, an indicator light in the cab alerts the operator. It's an early warning that helps avert major final-drive failure and expense.



These dozers were designed with rippers in mind. Rear attachment mounting points are an integral part of their mainframes, not add-ons.



Vertical spin-on filters allow quick, no-spill changes. Engine, hydraulics, and transmission utilize a common oil, further simplifying service.



Easy-to-read sight gauges provide quick daily checks of hydraulic, transmission, and final-drive seal fluids. Monitor signals an alert should final-drive seal levels drop.

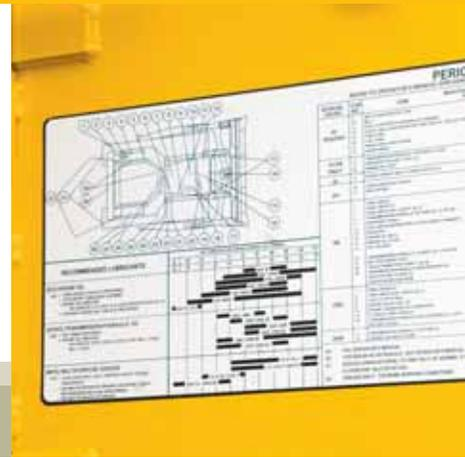

Convenient lube and periodic maintenance chart ensures that nothing gets overlooked.

Easier maintenance is an open-and-shut case.

Servicing big equipment doesn't have to be a big production. As with all John Deere dozers, ease of maintenance and low daily operating costs are a high priority on the J-Series. Large, hinged side shields and compartment doors provide wide-open access to dipsticks, fill tubes, maintenance-free batteries, and vertical spin-

on filters. Same-side service points make quick work of the daily routine, and drivetrain service intervals have been extended. These and other time-saving features such as an easy-to-clean undercarriage, quick-to-replace hydraulic hoses, and designed-in diagnostics help keep downtime and daily operating costs to a minimum.

Smooth idler-to-sprocket covers shed material, and wide space between the track frames and mainframe further eases clean-out.

Environmental drains on fluid compartments help make changes easier and less messy.

Five-hundred-hour engine oil and 2,000-hour transmission and hydraulic fluid intervals decrease downtime and expense.

Advanced diagnostic monitor provides easy-to-understand messages, for quick troubleshooting without special tools.

Large hinged doors provide ample access for daily checks and periodic maintenance. Daily checks are limited to hydraulic oil and engine oil and coolant levels.



Essential maintenance items such as engine coolant, fuel pre-cleaner and final fuel filter, engine oil filters, hydrostatic oil filter, air filter, and dipsticks are grouped on the right side for time-saving convenience.



With no need to disconnect linkages, hydraulics, or wiring, the operator station tilts in only minutes. For wide-open access to drivetrain and hydraulic components.

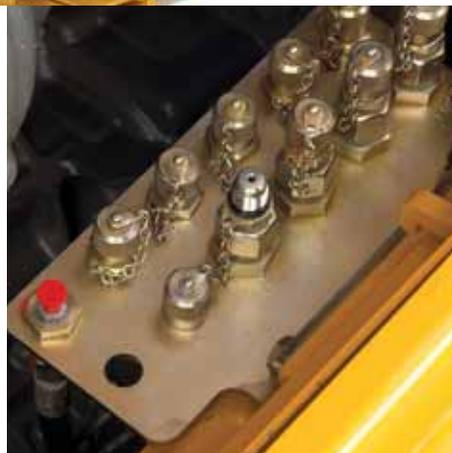

Remote drive-system test ports and available fluid-sample ports simplify preventive maintenance and troubleshooting for increased uptime.



Perforated hood and side screens act as a "first filter," preventing entry of most debris. Side-by-side wide-fin radiator and charge-air cooler resist plugging.

Specifications

Engine		950J / 950J LGP	
Manufacturer and Model	Liebherr D 936-L A6	
Non-Road Emission Standards	certified to EPA Tier 3 emissions	
Cylinders	in-line 6	
Displacement	641 cu. in. (10.5 L)	
Net Power (ISO9249)	247 hp (184 kW) @ 1,600 rpm	
Net Peak Torque (ISO9249)	937 lb.-ft. (1270 Nm) @ 1,400 rpm	
Aspiration	intercooled and turbocharged diesel	
Lubrication	pressure system with full-flow spin-on filter and integrated oil-to-water cooler	
Air Cleaner	dual stage dry type with safety element and aspirated precleaner, with in-cab restriction indicator	
Cold-Starting Aid	intake-mounted air-inlet heater	
Slope Operation (maximum angle)	45 deg.	
Cooling			
Engine	suction-type cooling fan, front mounted, thermostatically controlled; hydraulically driven with perforated engine side shields and heavy-duty front grille with tilt hose protection	
Engine Coolant Rating	-34 deg. F (-37 deg. C)	
Powertrain			
Transmission	automatic dual-path, hydrostatic drive; load-sensing feature automatically adjusts speed and power to match changing load conditions; each individual track is powered by a variable-displacement pump and motor combination; speed-in-grip with fingertip speed control; infinite speed control; decelerator pedal controls ground speed to stop; dealer selectable transmission operating parameters; transmission diagnostic test ports	
Maximum Speeds (forward and reverse)	6.8 mph (11 km/h)	
Steering	single-lever steering, direction control, and counterrotation; full power turns and infinitely variable track speeds provide unlimited maneuverability and optimum control	
Final Drives	double-reduction planetary final drives mounted independent of track frame and dozer push frame for isolation from shock loads; hydraulic drive motors are mounted to the mainframe; final drives are double sealed with electronic seal-integrity indicator	
Drawbar Pull	82,055 lb. (365 kN) @ .09 mph (1.5 km/h)	
Service Brakes	hydrostatic (dynamic) braking stops the machine whenever the direction/steering control lever is moved to neutral or whenever the combined decelerator/brake pedal is fully depressed	
Parking Brakes	exclusive park brake feature engages wet, multiple-disc brakes whenever the engine stops, the combined decelerator/brake pedal is fully depressed, the park lock lever is placed in the park position, the emergency travel stop button is depressed on the dash, the F-N-R control is in the neutral position for more than 7 seconds, or machine motion is sensed with F-N-R in neutral position; machine cannot be driven with brake applied, reducing wear-out or need for adjustment	
Hydraulics			
Load-sensing proportional pump-flow control, variable-displacement axial-piston pump			
Pump Flow	68 gpm (258 L/min.) @ 1,600 rpm	
System Relief Pressure	3,770 psi (26 000 kPa)	
Filter, Return Oil	20 micron with 5-micron bypass filter	
Control	single joystick lever	
Electrical			
Voltage	24 volt	
Number of Batteries	2	
Battery Capacity	1,000 CCA	
Alternator Rating	80 amp	
Lights	6 total: front (4) and rear (2) cab work lights, and rear reflectors (2)	
Undercarriage		950J	950J LGP
Tracks	track frame with front and rear track guides and sprocket guard; features deep-heat-treated, sealed, and lubricated track links and through-hardened, sealed, and lubricated rollers for maximum wear resistance; extreme-duty shoes for severe applications	
Track Gauge (standard)	6 ft. 6 in. (1981 mm)	7 ft. 2 in. (2184 mm)

Undercarriage (continued)	950J	950J LGP
Chain	sealed and lubricated	sealed and lubricated
Track/Carrier Rollers (each side)	7/2	8/2
Track Chain Pitch	8.5 in. (216 mm)	8.5 in. (216 mm)
Sprocket Segments (each side)	5	5
Shoes (each side)	40	43
Ground Contact Area		
22-in. (560 mm) Grouser Width	5,203 sq. in. (33 566 cm ²)	
24-in. (610 mm) Grouser Width	5,667 sq. in. (36 563 cm ²)	
26-in. (660 mm) Grouser Width	6,132 sq. in. (39 560 cm ²)	
32-in. (812 mm) Grouser Width		8,347 sq. in. (53 852 cm ²)
36-in. (914 mm) Grouser Width		9,396 sq. in. (60 616 cm ²)
Track Length on Ground	9 ft. 10 in. (2997 mm)	10 ft. 11 in. (3316 mm)
Oscillation at Front Idler	5.6 in. (141 mm)	6.2 in. (158 mm)
Ground Pressure (with blade)		
22 in. (560 mm)	11.0 psi (76 kPa)	
24 in. (610 mm)	10.1 psi (70 kPa)	
26 in. (660 mm)	9.3 psi (64 kPa)	
32 in. (812 mm)		7.2 psi (50 kPa)
36 in. (914 mm)		6.5 psi (45 kPa)

Serviceability 950J / 950J LGP

Integral bottom protection; engine and mid-frame reinforced guards; hydraulic hose "O"-ring face seal connectors

Sight Gauges. hydraulic reservoir

Refill Capacities*

Fuel Tank	141 gal. (535 L)
Cooling System with Recovery Tank	16.4 gal. (62 L)
Splitter Drive	1.5 gal. (5.6 L)
Engine Oil with Filter	11.4 gal. (43 L)
Final Drive (each)	5.2 gal. (19.5 L)
Hydraulic/Transmission Reservoir and Filter	50 gal. (189 L)

*Please follow drain and refill procedures and volumes listed in the operator's manual.

Operating Weights	950J	950J LGP
SAE Operating Weight Includes Standard Equipment, Blade, Full Fuel Tank, and 175-lb. (79 kg) Operator		
24-in. (610 mm) Extreme-Service Shoes	56,361 lb. (25 565 kg)	
32-in. (812 mm) Extreme-Duty Shoes		59,255 lb. (26 877 kg)
Tractor Shipping Weight Includes Coolant, Lubricants, and 20% Fuel (without blade or attachments)	47,933 lb. (21 742 kg)	50,550 lb. (22 929 kg)
Optional Components		
22-in. (560 mm) Extreme-Service Grousers	– 401 lb. (– 182 kg)	
24-in. (610 mm) Extreme-Service Grousers	in base	
26-in. (660 mm) Moderate-Service Grousers	– 639 lb. (– 290 kg)	
32-in. (812 mm) Extreme-Duty Shoes		in base
36-in. (914 mm) Moderate-Service Grousers		825 lb. (374 kg)
Automatic Reversing Fan with High-Demand Cooling Package	289 lb. (131 kg)	289 lb. (131 kg)
Auxiliary Hydraulic Controls and Plumbing for Rear Attachments		
Dual-Function	278 lb. (126 kg)	278 lb. (126 kg)
Single-Function	150 lb. (68 kg)	150 lb. (68 kg)
Blade Liner for Semi-U Blade	937 lb. (425 kg)	937 lb. (425 kg)
Bolt-on Rock Guards	525 lb. (238 kg)	615 lb. (279 kg)
Bottom Tank Guard	419 lb. (190 kg)	419 lb. (190 kg)
Extended Rigid Drawbar	804 lb. (365 kg)	804 lb. (365 kg)
Final Drive Seal Guards	200 lb. (91 kg)	N/A
Landfill Package	1,418 lb. (643 kg)	N/A
Powered Cab Air Precleaner System*	249 lb. (113 kg)	249 lb. (113 kg)
Push Plate		
Semi-U Blade	569 lb. (258 kg)	569 lb. (258 kg)
Straight Blade	472 lb. (214 kg)	472 lb. (214 kg)
Rear Counterweight	7,055 lb. (3200 kg)	7,055 lb. (3200 kg)
With Storage Compartment	6,120 lb. (2776 kg)	6,120 lb. (2776 kg)
Spill Guard for Semi-U Blade	157 lb. (71 kg)	157 lb. (71 kg)
Wear Plates for Push Beams	436 lb. (198 kg)	436 lb. (198 kg)

*Note: Adds 12 in. (296 mm) to overall tractor height.

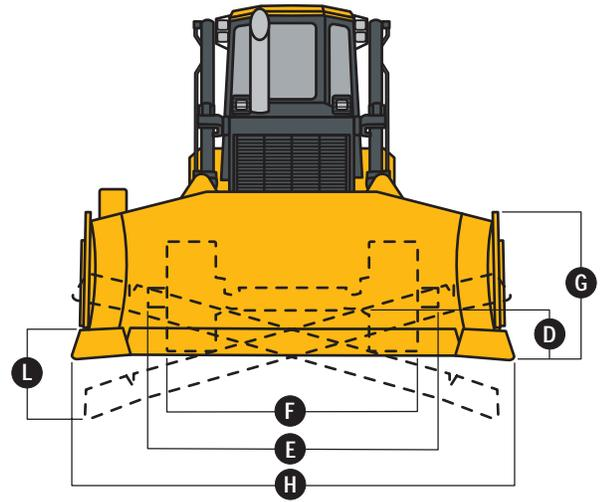
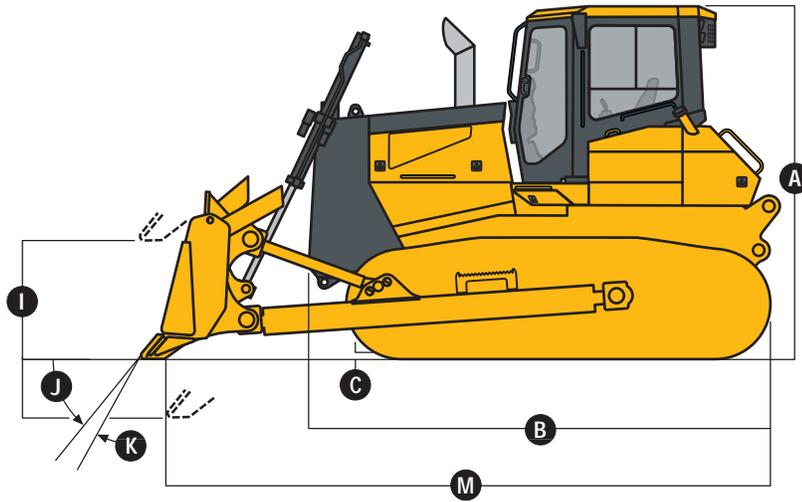

Machine Dimensions (with straight blade)

950J

950J LGP

A Overall Height Over Cab	11 ft. 3 in. (3.43 m)	11 ft. 6 in. (3.50 m)
B Overall Length (without blade)	15 ft. 3 in. (4.66 m)	15 ft. 5 in. (4.69 m)
C Height of Grousers	2.8 in. (71.5 mm)	2.8 in. (71.5 mm)
D Ground Clearance	21 in. (545 mm)	21 in. (545 mm)
E Total Width Over Blade-Mounting Trunnions	9 ft. 10 in. (3.00 m)	11 ft. 10 in. (3.60 m)
F Overall Width with Extreme-Duty Single-Bar Grouser Shoes		
22 in. (560 mm)	8 ft. 4 in. (2.54 m)	
24 in. (610 mm)	8 ft. 6 in. (2.59 m)	
26 in. (660 mm)	8 ft. 8 in. (2.64 m)	
32 in. (812 mm)		9 ft. 10 in. (2.99 m)
36 in. (914 mm)		10 ft. 2 in. (3.09 m)

Blade Specs

Blade Weight with Standard Cutting Edges and Cupped End Bits without Spill Guard	4,835 lb. (2193 kg)	4,996 lb. (2266 kg)
Weight of Push Beams and Tilt Cylinders With Mechanical Pitch Adjustment	3,594 lb. (1630 kg)	3,708 lb. (1682 kg)
With Power Pitch	4,023 lb. (1825 kg)	4,138 lb. (1877 kg)
SAE Capacity	9.4 cu. yd. (7.19 m ³)	7.9 cu. yd. (6.04 m ³)
G Height	5 ft. 1 in. (1.55 m)	4 ft. 3 in. (1.3 m)
H Width	12 ft. 1 in. (3.7 m)	14 ft. 9 in. (4.5 m)
I Lifting Height	4 ft. 0 in. (1.22 m)	3 ft. 10 in. (1.17 m)
J Blade Digging Depth	20 in. (511 mm)	24 in. (610 mm)
K Maximum Blade Pitch Adjustment	10 deg.	10 deg.
L Maximum Tilt	37 in. (930 mm)	37 in. (933 mm)
M Overall Length	19 ft. 10 in. (6.05 m)	19 ft. 6 in. (5.9 m)

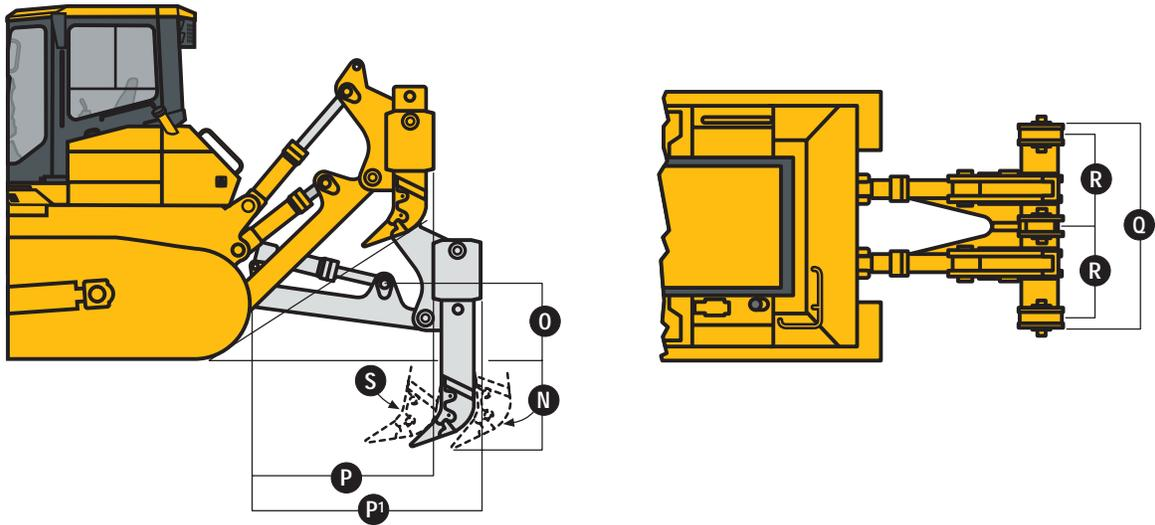

Rear Ripper

950J / 950J LGP

3-shank parallelogram ripper with hydraulic pitch adjustment and 2 hole shank positions

Weight	7,286 lb. (3305 kg)
N Ripping Depth	
Maximum	29 in. (749 mm)
Minimum	18 in. (449 mm)
O Lifting Height	
Maximum	30 in. (755 mm)
Minimum	18 in. (459 mm)
P Overall Length (attachment raised)	5 ft. 2 in. (1.6 m)
P' Overall Length (attachment lowered)	6 ft. 4 in. (1.9 m)
Q Toolbar Width	7 ft. 2 in. (2.2 m)
R Distance Between Teeth	3 ft. 3 in. (1.0 m)
S Maximum Pitch Adjustment	25 deg.

Specifications

Engine	1050J
Manufacturer and Model	Liebherr D 946-L A6
Non-Road Emission Standards	certified to EPA Tier 3 emissions
Cylinders	in-line 6
Displacement	732 cu. in. (12.0 L)
Net Power (ISO9249)	335 hp (250 kW) @ 1,800 rpm
Net Peak Torque (ISO9249)	1,254 lb.-ft. (1700 Nm) @ 1,400 rpm
Aspiration	intercooled and turbocharged diesel
Lubrication	pressure system with full-flow spin-on filter and integrated oil-to-water cooler
Air Cleaner	dual-stage dry type with safety element and aspirated precleaner, with dash-mounted restriction indicator
Cold-Starting Aid	intake-mounted air-inlet heater
Slope Operation (maximum angle)	45 deg.
Cooling	
Engine	suction-type cooling fan, front mounted, thermostatically controlled; hydraulically driven with perforated engine side shields and heavy-duty front grille
Engine Coolant Rating	-34 deg. F (-37 deg. C)
Powertrain	
Transmission	automatic dual-path, hydrostatic drive; load-sensing feature automatically adjusts speed and power to match changing load conditions; each individual track is powered by a variable-displacement pump and motor combination; speed-in-grip with fingertip speed control; infinite speed control; decelerator pedal controls ground speed to stop; dealer selectable transmission operating parameters; transmission diagnostic test ports
Maximum Speeds (forward and reverse)	6.8 mph (11 km/h)
Steering	single-lever steering, direction control, and counterrotation; full power turns and infinitely variable track speeds provide unlimited maneuverability and optimum control
Final Drives	double-reduction planetary final drives mounted independent of track frame and dozer push frame for isolation from shock loads; hydraulic drive motors are mounted to the mainframe; final drives are double sealed with electronic seal-integrity indicator
Drawbar Pull	116,901 lb. (520 kN) @ .09 mph (1.5 km/h)
Service Brakes	hydrostatic (dynamic) braking stops the machine whenever the direction/steering control lever is moved to neutral or whenever the combined decelerator/brake pedal is fully depressed
Parking Brakes	exclusive park brake feature engages wet, multiple-disc brakes whenever the engine stops, the combined decelerator/brake pedal is fully depressed, the park lock lever is placed in the park position, the emergency travel stop button is depressed on the dash, the F-N-R control is in the neutral position for more than 7 seconds, or machine motion is sensed with F-N-R in neutral position; machine cannot be driven with brake applied, reducing wear-out or need for adjustment
Hydraulics	
Load-sensing proportional pump-flow control, variable-displacement piston pump	
Pump Flow	68 gpm (258 L/min.) @ 1,600 rpm
System Relief Pressure	3,700 psi (26 000 kPa)
Filter, Return Oil	20 microns with 5-micron bypass filter
Control	single joystick lever
Electrical	
Voltage	24 volt
Number of Batteries	2
Battery Capacity	1,000 CCA
Alternator Rating	80 amp
Lights	cab mounted (6 total): front (4) and rear (2); and rear reflectors (2)

Undercarriage

1050J

Tracks	track frame with front and rear track guides and sprocket guard; features deep-heat-treated, sealed, and lubricated track links and through-hardened, sealed, and lubricated rollers for maximum wear resistance; extreme-duty shoes for severe applications	
Track Gauge (standard)	7 ft. 2 in. (2180 mm)	
Chain	sealed and lubricated	
Track/Carrier Rollers (each side)	7/2	
Track Chain Pitch	8.5 in. (216 mm)	
Sprocket Segments (each side)	5	
Shoes (each side)	44	
Ground Contact Area		
22-in. (560 mm) Grouser Width	5,512 sq. in. (35 560 cm ²)	
24-in. (610 mm) Grouser Width	6,004 sq. in. (38 735 cm ²)	
26-in. (660 mm) Grouser Width	6,496 sq. in. (41 910 cm ²)	
28-in. (710 mm) Grouser Width	6,998 sq. in. (45 149 cm ²)	
Track Length on Ground	10 ft. 5 in. (3175 mm)	
Oscillation at Front Idler	13 in. (330 mm)	
	<i>semi-U dozer blade with power tilt and mechanical pitch adjustment</i>	<i>U blade with power tilt and mechanical pitch adjustment</i>
Ground Pressure (with blade)		
22 in. (560 mm)	14.2 psi (98 kPa)	14.8 psi (102 kPa)
24 in. (610 mm)	12.9 psi (89 kPa)	13.3 psi (92 kPa)
28 in. (710 mm)	11.2 psi (77 kPa)	11.6 psi (80 kPa)

Serviceability

Integral bottom protection; engine and mid-frame reinforced guards; hydraulic hose "O"-ring face seal connectors

Sight Gauges hydraulic reservoir

Refill Capacities*

Fuel Tank	172 gal. (650 L)
Cooling System with Recovery Tank	15 gal. (57 L)
Splitter Drive	1.5 gal. (5.5 L)
Engine Oil with Filter	9.0 gal. (34 L)
Final Drive (each)	4.9 gal. (18.5 L)
Hydraulic/Transmission Reservoir and Filter	55.5 gal. (210 L)

*Please follow drain and refill procedures and volumes listed in the operator's manual.

Operating Weights

SAE Operating Weight Includes Standard Equipment, 24-in. (610 mm) Extreme-Service Shoes, Blade, Full Fuel Tank, and 175-lb. (79 kg) Operator	77,843 lb. (35 309 kg)
Tractor Shipping Weight Includes Coolant, Lubricants, and 20% Fuel (without blade or attachments)	64,346 lb. (29 187 kg)

Optional Components

22-in. (560 mm) Extreme-Service Grousers	– 529 lb. (– 240 kg)
28-in. (710 mm) Extreme-Service Grousers	1,014 lb. (460 kg)
Automatic Reversing Fan with High-Demand Cooling Package	708 lb. (321 kg)
Auxiliary Hydraulic Controls and Plumbing for Rear Attachments	313 lb. (142 kg)
Blade Liner for Semi-U Blade	1,311 lb. (595 kg)
Bottom Tank Guard	699 lb. (317 kg)
Full-Length Rock Guards (bolt-on)	1,036 lb. (470 kg)
Pin Puller (hydraulic)	130 lb. (59 kg)
Powered Cab Air Precleaner System*	249 lb. (113 kg)
Rear Counterweight	
With Drawbar	8,772 lb. (3979 kg)
With Storage Compartment	7,714 lb. (3499 kg)
Wear Plates for Push Beams	752 lb. (341 kg)

*Note: Adds 12 in. (296 mm) to overall tractor height.

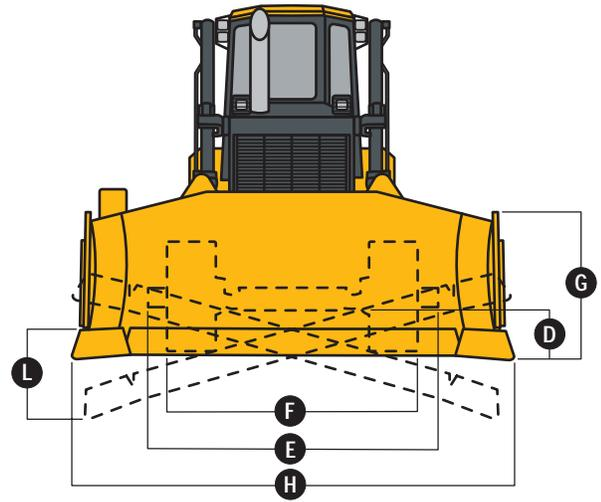
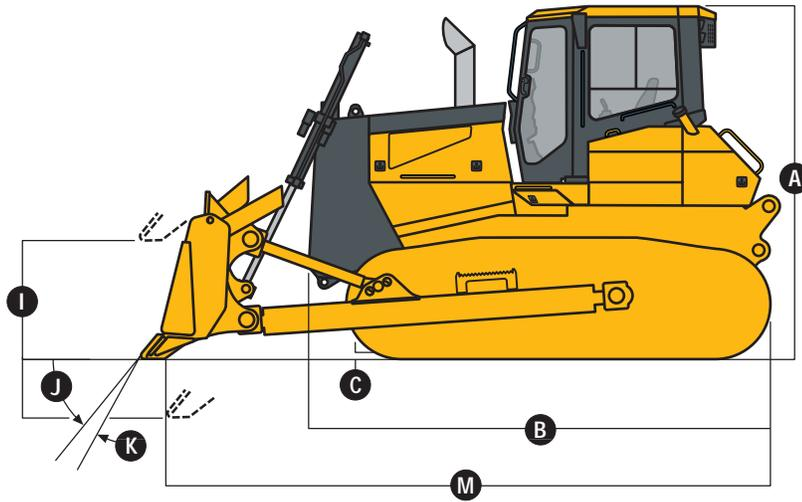

Machine Dimensions

1050J

A Overall Height Over Cab	11 ft. 11 in. (3.63 m)
B Overall Length (without blade)	16 ft. 0 in. (4.88 m)
C Height of Grousers	3 in. (84 mm)
D Ground Clearance	25 in. (635 mm)
E Total Width Over Blade-Mounting Trunnions	10 ft. 4 in. (3.15 m)
F Overall Width with Extreme-Duty Single-Bar Grouser Shoes	
22 in. (560 mm)	9 ft. 0 in. (2.74 m)
24 in. (610 mm)	9 ft. 2 in. (2.79 m)
26 in. (660 mm)	9 ft. 4 in. (2.84 m)
28 in. (710 mm)	9 ft. 6 in. (2.90 m)

Blade Specs

semi-U dozer blade with push beams, cupped end bits, and tilt cylinder

U blade with push beams, cupped end bits, and tilt cylinder

Weight

With Mechanical Pitch Adjustment	13,318 lb. (6041 kg)
With Power Pitch	13,567 lb. (6154 kg)
With Standard Cutting Edges without Spill Guard	7,033 lb. (3190 kg)
SAE Capacity	11.6 cu. yd. (8.92 m ³)

14,908 lb. (6762 kg)
15,157 lb. (6875 kg)
8,622 lb. (3911 kg)
15.3 cu. yd. (11.7 m ³)

G Height	5 ft. 5 in. (1.7 m)
H Width	13 ft. 3 in. (4.04 m)
I Lifting Height	4 ft. 7 in. (1.4 m)
J Blade Digging Depth	22 in. (570 mm)
K Maximum Blade Pitch Adjustment	10 deg.
L Maximum Tilt	3 ft. 2 in. (972 mm)
M Overall Length	21 ft. 4 in. (6.5 m)

5 ft. 5 in. (1.7 m)
14 ft. 2 in. (4.3 m)
4 ft. 7 in. (1.4 m)
22 in. (570 mm)
10 deg.
3 ft. 5 in. (1043 mm)
22 ft. 8 in. (6.9 m)

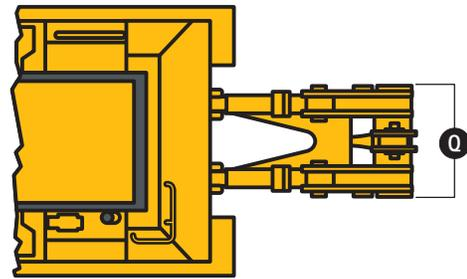
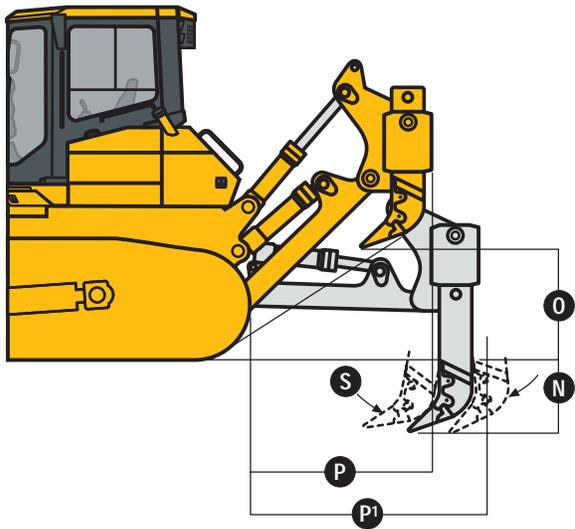

1050J DOZER WITH SINGLE-SHANK REAR RIPPER

Rear Ripper

1050J

Parallelogram ripper with hydraulic pitch adjustment

	<i>single-shank (3-hole height adjustment in each shank)</i>	<i>multi-shank (3) with hydraulic pitch (2-hole height adjustment in each shank)</i>
Weight	7,974 lb. (3617 kg)	10,509 lb. (4767 kg)
N Ripping Depth		
Maximum	3 ft. 11 in. (1201 mm)	2 ft. 7 in. (791 mm)
Minimum	17 in. (421 mm)	19 in. (476 mm)
O Lifting Height		
Maximum	3 ft. 5 in. (1040 mm)	3 ft. 3 in. (985 mm)
Minimum	10 in. (260 mm)	19 in. (476 mm)
P Overall Length (attachment raised)	6 ft. 0 in. (1.8 m)	6 ft. 0 in. (1.8 m)
P' Overall Length (attachment lowered)	7 ft. 9 in. (2.4 m)	7 ft. 9 in. (2.4 m)
Q Toolbar Width	4 ft. 4 in. (1.3 m)	8 ft. 0 in. (2.4 m)
R Distance Between Teeth		3 ft. 7 in. (1.1 m)
S Maximum Pitch Adjustment	31 deg.	31 deg.

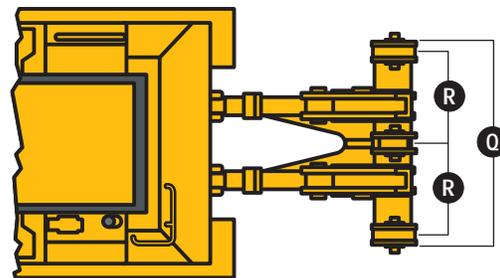
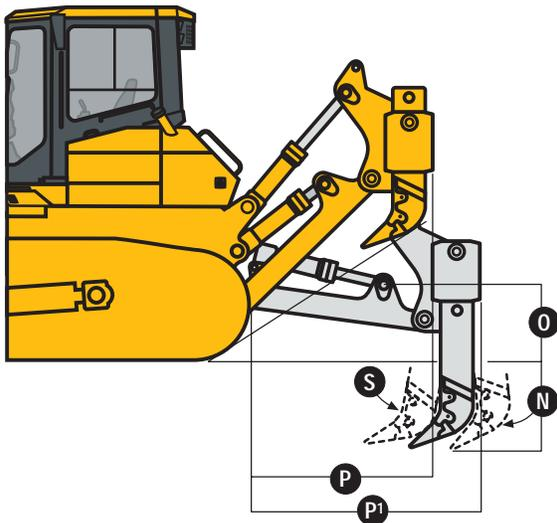

1050J DOZER WITH MULTI-SHANK REAR RIPPER

950J / 1050J CRAWLER DOZERS

Key: ● Standard equipment ▲ Optional equipment

*See your John Deere dealer for further information.

950J	1050J	Engine
●	●	Certified to EPA Tier 3 emissions
●	●	Direct-injection, intercooled, turbocharged in-line 6-cylinder
●		Liebherr D 936-L A6
●	●	Liebherr D 946-L A6
●	●	Spin-on engine oil filter with anti-drain-back valve
●	●	Fuel system includes precleaner with water separator
●	●	Oil-to-water engine oil cooler
●	●	Dual-element dry-type aspirated air cleaner with automatic dust ejector
●	●	Intake-mounted air-inlet heater start aid
●	●	Key start switch with electric fuel shutoff
●	●	Electronic engine throttle control
▲	▲	Alternator air prescreener

Cooling

●	●	Engine coolant rated -34 deg. F (-37 deg. C)
●	●	Hydraulically driven, front-mounted suction-type cooling fan
●	●	Radiator, heavy-duty, 5 fins per in.
●	●	Transmission oil cooler with hydraulically driven cooling fan
●	●	Transmission cooler rated 5 fins per in.
●	●	Hinged, reinforced radiator guard
▲	▲	Reversing fan drives available for engine and hydraulic cooling systems

Powertrain

●	●	Dual-path hydrostatic transmission
●	●	Automatic load sensing for speed and power management
●	●	Automatic-tracking steering control with single-lever steering, direction/speed control with counter-rotation
●	●	Infinite speed control; speed-in-grip with fingertip speed control; dealer-selectable transmission operating parameters
●	●	Double-reduction final drives with wet multi-disc brakes
●	●	Integral final-drive seal protection
●	●	Primary and secondary service brakes
▲	▲	Engine air dual-stage precleaner with debris screen

Hydraulics

●	●	Load-sensing proportional flow pump
●	●	68 gpm (258 L/min.) pump flow
●	●	Hydraulic/transmission oil reservoir with service shutoff, 49.9 gal. (189 L)
●	●	Hydraulic/transmission oil reservoir with service shutoff, 55.5 gal. (210 L)
●	●	Pilot-pressure control system
●	●	Two-function hydraulic valve with quick-drop blade feature; single-lever blade control compatible for additional functions
●	●	20/5-micron replaceable dual-stage filter element

950J	1050J	Hydraulics (continued)
●	●	"O"-ring seal connectors
●	●	Hydraulic diagnostic ports

Electrical

●	●	24-volt system
●	●	80-amp alternator
●	●	Dual 1,000-CCA batteries
●	●	Circuit breakers
●	●	Positive-terminal battery covers
●	●	Electrically activated battery
●	●	Master disconnect
●	●	Backup warning alarm
●	●	Cab work lights (6), front (4) and rear (2)
▲	▲	Additional grille-mounted front lights (2)
▲	▲	Additional lift-cylinder lights (4)
▲	▲	Additional rear cab-mounted lights (2)
▲	▲	JDLINK™

Undercarriage

●	●	Oscillating track frames
●	●	Heavy-duty, sealed and lubricated track chain
●	●	Hydraulic track adjusters with dirt cover
●	●	Front idler and sprocket chain guides
●	●	Integrated track frame cover
●	●	Standard track frame, 78-in. (1980 mm) gauge
▲	●	Frame, 86-in. (2180 mm) gauge
▲	●	Extreme-duty grouser shoes, 22 in. (560 mm)
●	▲	Extreme-duty grouser shoes, 24 in. (610 mm)
▲	▲	Extreme-service grouser shoes, 26 in. (660 mm)
▲		Moderate-service grouser shoes, 26 in. (660 mm)
	▲	Extreme-service grouser shoes, 28 in. (710 mm)
▲		Moderate-service grouser shoes (LGP), 32 in. (812 mm)
▲		Moderate-service grouser shoes (LGP), 36 in. (914 mm)

Operator Station

●	●	Modular-design ROPS/FOPS isolation-mounted cab with left and right access
●	●	Heater (35,000 Btu) and air conditioning (28,000 Btu)
●	●	Pressurized and filtered ventilation with 3-speed blower
●	●	Front windshield washer, and rear and door window wipers
●	●	Dome light; rubber floor mats; interior-mounted rearview mirror; built-in operator's manual storage compartment with manual; cup holder
●	●	Slip-resistant steps and ergonomically located handholds
●	●	Comfort air suspension fabric seat with adjustable armrests, backrest, height, weight, and fore-aft

950J	1050J	Operator Station (continued)
●	●	Seat belt, 2 in. (50 mm), with retractor
●	●	Electronic monitor system with audible and visual warning for park brake; hydrostatic transmission pressure; engine air filter restriction; hydraulic/transmission filter restriction; low alternator voltage; final-drive seal leak indicator; transmission selected speed indicator
●	●	Indicators for engine rpm and hydraulic/hydrostatic oil temperature
●	●	Gauges, electric, illuminated for engine oil pressure; engine coolant temperature; fuel gauge; hour meter
●	●	Radio prepared and 12-volt/10-amp power port
▲	▲	AM/FM radio
▲	▲	Powered cab air-filtration system
▲	▲	Tank guard

Overall Vehicle

●	●	One-piece unitized mainframe
●	●	On-board cab-tilt system for full access to hydrostatic motors
●	●	Reinforced engine bottom guards
●	●	Rear retrieval hitch
●	●	Heavy-duty hinged bar-type grille
●	●	Locking vandal protection for perforated engine-access doors, and hydraulic- and transmission-access door
●	●	Storage compartments (2)

Attachments

▲		Semi-U blade with standard cutting edges, 145 in. (3690 mm), 9.43 cu. yd. (7.2 m ³) (standard and LT)
▲		Semi-U blade with standard cutting edges, 178 in. (4520 mm), 7.86 cu. yd. (6.0 m ³) (LGP)
▲	▲	Semi-U blade with standard cutting edges and cupped end bits, 159 in. (4030 mm)
▲	▲	U blade with standard cutting edges and cupped end bits, 170 in. (4318 mm)
▲	▲	Dual-function hydraulic controls and plumbing
▲	▲	Single-function hydraulic controls and plumbing
▲	▲	Dual blade-tilt cylinder for power pitch and tilt
▲	▲	Push plates, blade liners, and end bits
▲	▲	Multi-shank ripper
▲	▲	Single-shank ripper
▲	▲	Rear counterweight with drawbar (cannot be used with ripper)
▲	▲	Rigid heavy-duty drawbar (cannot be used with rear counterweight or ripper)
▲	▲	Rock guards



JOHN DEERE

DKA9501050J Litho in U.S.A. (07-04)

Net engine power is with standard equipment including air cleaner, exhaust system, alternator, and cooling fan at test conditions specified per ISO9249. No derating is required up to 10,000-ft. (3050 m) altitude.

Specifications and design subject to change without notice. Wherever applicable, specifications are in accordance with SAE standards. Except where otherwise noted, these specifications are based on units with standard equipment, modular ROPS/cabs, full fuel tanks, and 175-lb. (79 kg) operators.

